

ALH

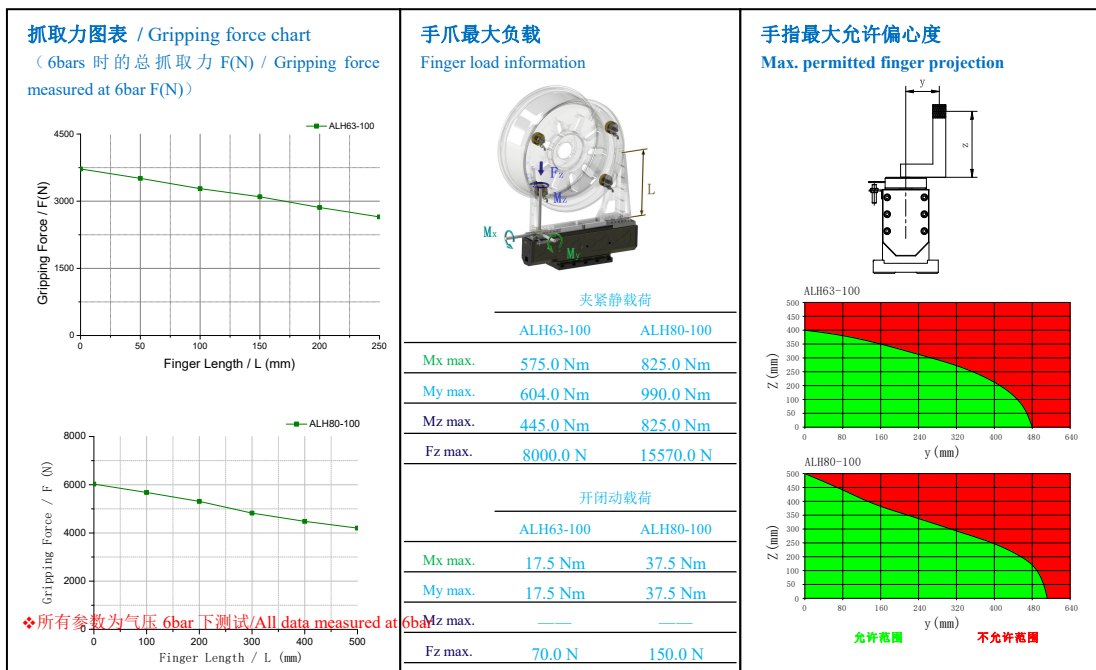

技术资料/Technical data

Description		ALH 63-100	ALH 80-100
手指单边行程 Stroke per finger	mm	100	100
理论夹持力-闭 Closing force	夹持力 $F=k*P$ (k:系数, P:bar)	N	555*P
	6bar 气压下夹持力	N	3330
理论夹持力-开 Opening force	夹持力 $F=k*P$ (k:系数, P:bar)	N	598*P
	6bar 气压下夹持力	N	3588
使用压力范围 Max./Min. operating pressure	bar	3/8	3/8
自重 Self weight	Kg	22	25
空气消耗量/周期 Air consumption per double stroke	cm <sup>3</sup>	1246	1055
开/闭时间 Closing/opening time	s	0.8/0.8	1.0/1.0
重复精度 Repeat accuracy	mm	0.1	0.1
最大手指长度 Max. permitted finger length	mm	400	500
单个手指最大重量 Max. permitted weight per finger	Kg	7	15
适应最小/最大环境温度 Min./Max. ambient temperature	°C	标准型 : 5/80 高温型 (-R) : 5/200	标准型 : 5/80 高温型 (-R) : 5/200
IP 等级 IP class		46	46

◇P: 空气压力[bar], 手指夹持工件作用点到手指安装面距离 L [mm] \*重复精度: 连续动作 100 次后检测值

◇P: Pressure [bar], L:The distance from the point of the Finger gripping the workpiece to the finger mounting surface [mm] \*Repeat accuracy is defined as the spread of the limit position after 100 consecutive strokes

尺寸图/Dimensions

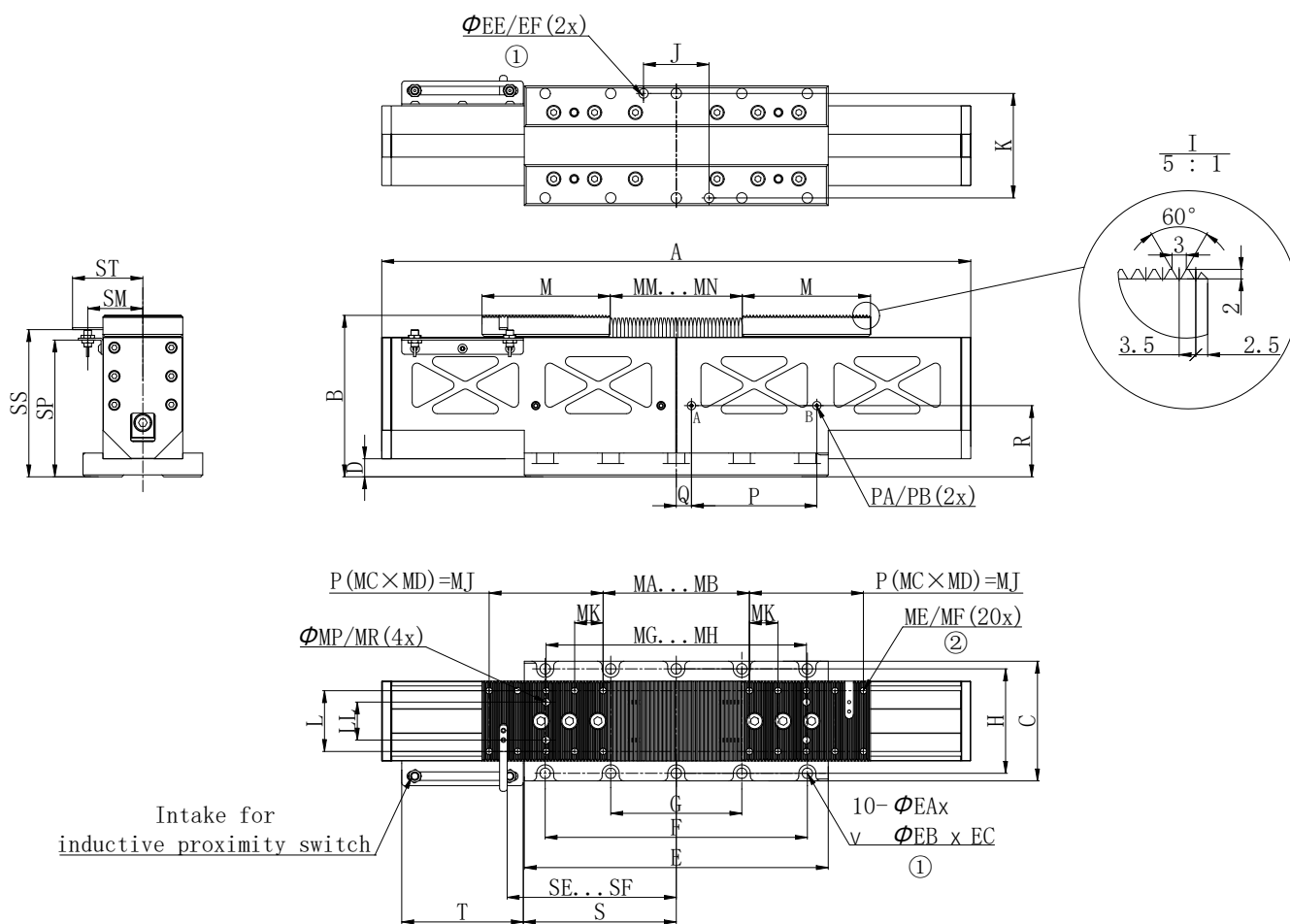

Intake for inductive proximity switch

- A、手爪张开主/直接连接进气口      A Main/direct connection, gripper opening
- B 手爪闭合主/直接连接进气口      B Main/direct connection, gripper closing
- ① 手爪连接      Gripper connection
- ② 手指连接      Finger connection

型号	A	B	C	D	E	EA	EB	EC	EE	EF	F	G	H	J	K	L	LL	M	MA	MB	MC
ALH63-100	620	170	126	19	320	11	18	11	10H7	15	276	138	110	69±0.02	110±0.02	64	40±0.02	135	154	354	30
ALH80-100	630	192	126	33	320	11	18	11	10H7	15	276	138	110	69±0.02	110±0.02	64	40±0.02	135	154	354	30

型号	MD	ME	MF	MG	MH	MJ	MK	MM	MN	MP	MR	P	PA	PB	Q	R	S	SE	SF	SM	SP	SS	ST	T
ALH63-100	4	M8	15	274	474	120	30	139	339	8H7	12	132	G1/8	8	17	75	161	178	278	58	144	155	74	128
ALH80-100	4	M8	15	274	474	120	30	139	339	8H7	12	132	G1/4	12	17	99	166	178	278	63.5	166	177	74	128