

Sizes
70...160

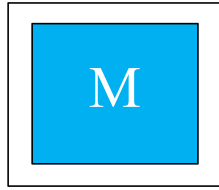

Weight
5...20Kg

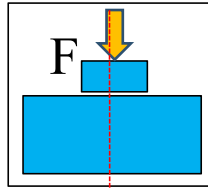

Axial Force
500...2200N

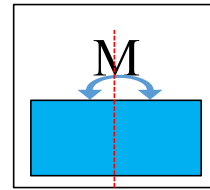

Torque
57...260Nm

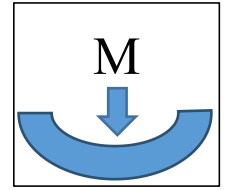

Bending moment
60...240Nm

应用案例 / Application example

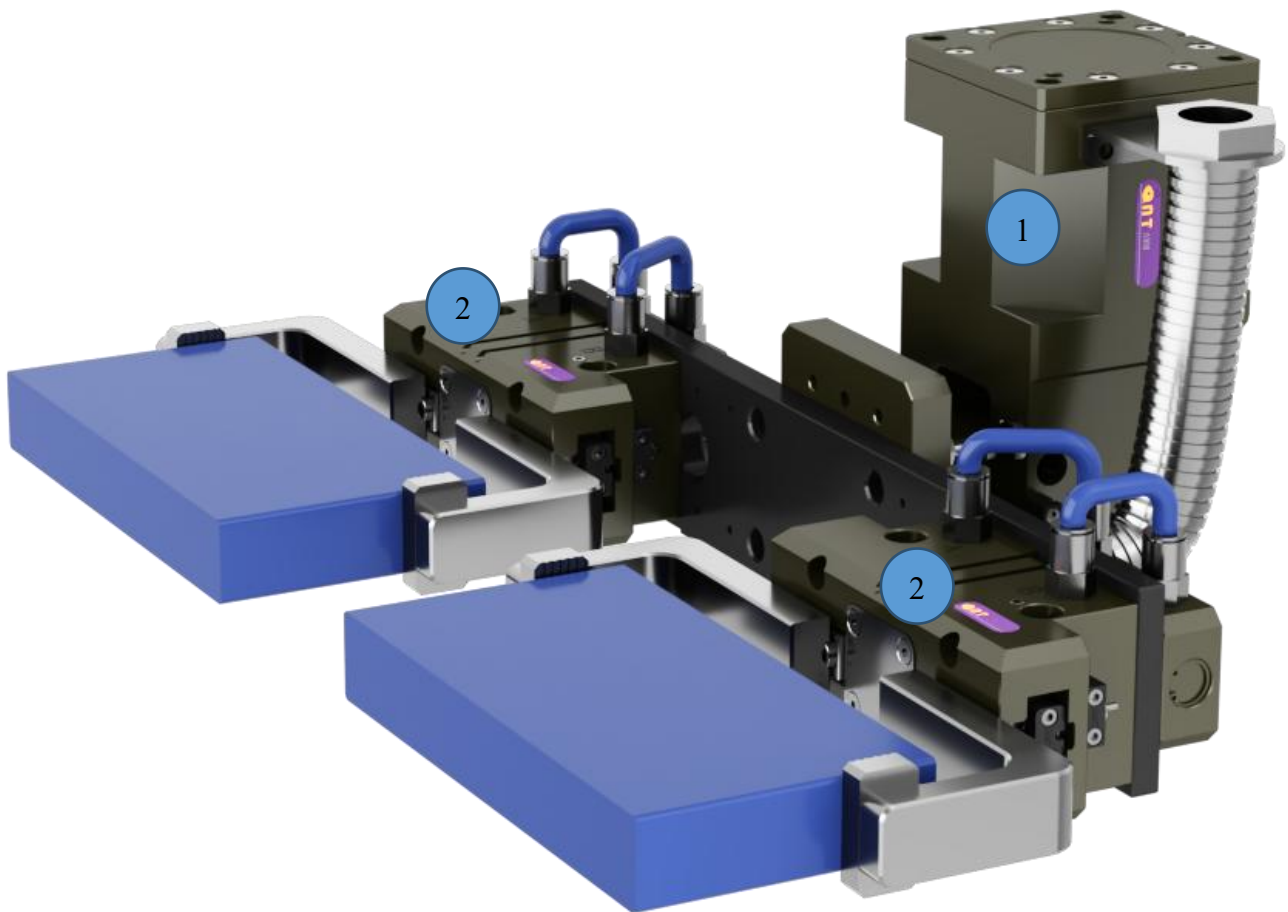

- ① AWM 125 旋转模块
- ② AGN 125 2指平动手爪

- AWM 125 Swivel unit
- AGN 125 2-Finger Gripper series

旋转手腕 / Swivel head

- 高起重扭矩
- 旋转角度 90°
- 可加装锁定装置
- 内置滚动轴承，有效减少轴与轴孔的摩擦
- 配置磁性传感器安装槽



- High lifting torque
- Swivel angle 180°
- Can be equipped with locking device
- Build-in rolling bearing, effectively reduce the friction between shaft and the hole
- Configuring sensor trenches

传感系统 Sensor system

接近开关 / Proximity switch (选购/Order)



型号(NO.)	
NPN	WPS-8GM35N
PNP	WPS-8GM35P

磁性开关 / Magnetic Sensor (选购/Order)



型号(NO.)	
NPN	WMS-M9N
PNP	WMS-M9P

- 传感器成对使用
- 磁性传感器不适用于连接具有磁性的连接板或环境为磁场环境和环境温度大于 80℃ 下使用
- Two sensors (NO contacts) are required for each swivel unit.

AWM

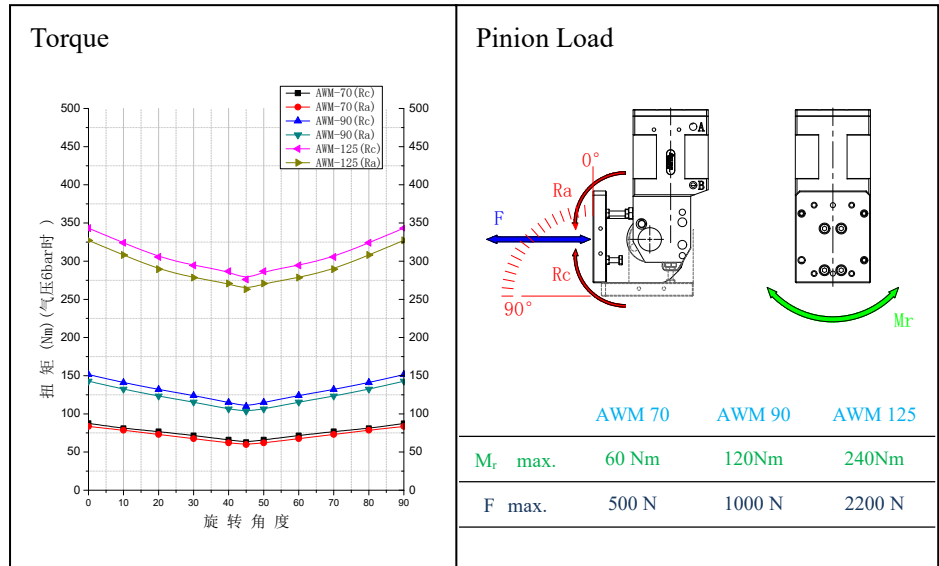

❖所有参数为气压 6bar 下测试/All data measured at 6bar

技术资料 Technical data

Description		AWM 70	AWM 90	AWM 125
6bar 压力下旋转扭矩 (90° -0°) (Rc) Torque	旋转扭矩 $T=k*P$ (k:系数, P:bar) [Nm]	>10*P	>17.5*P	>45*P
	6bar 气压下旋转扭矩 [Nm]	>10*P	>17.5*P	>45*P
6bar 压力下旋转扭矩 (0° -90°) (Ra) Torque	旋转扭矩 $T=k*P$ (k:系数, P:bar) [Nm]	>9.5*P	>16.8*P	>42*P
	6bar 气压下旋转扭矩 [Nm]	>9.5*P	>16.8*P	>42*P
旋转角度 Rotating angle	[°]	90	90	90
调整角度 Adjustability of end positions	[°]	2.0	2.0	2.0
IP 等级 IP class		64	64	64
旋转时间 Swiveling time with middle attached load	[s]	1.5	2	3
自重 Self weight	[Kg]	4.5	10	20
空气消耗量 Air consumption per double stroke	[Cm³]	486	930	2282
使用压力 Nominal pressure	[bar]	6	6	6
最大使用压力 Maximum pressure	[bar]	8	8	8
最小使用压力 Minimum pressure	[bar]	3	3	3
空气连接口 Air connection		G1/8	G1/8	G1/4
适应最小/最大环境温度 Min./max. ambient temperature	[°C]	5~60	5~60	5~60
重复精度 Repeat accuracy	[°]	0.1	0.2	0.5
缓冲装置 Buffering mode		标准型: 无 缓冲型: -B		

❖P: 空气压力[bar] *重复精度: 连续动作 100 次后检测值

❖P: Pressure[bar] *Repeat accuracy is defined as the spread of the limit position after 100 consecutive strokes.

尺寸图/Dimensions

AWM

90° 位置

限位调节

-B 缓冲装置 (选购) / Buffering mode (Order)

订购号 (Order No)	适配型号	S	T
HDBM 70	AWM-70	130.5	150
HDBM 90	AWM-90	168	172
HDBM 125	AWM-125	205	245

型号	A	B	C	D	E	F	G	GA	GB	GD	GE	H	HA	HB	K	KA	KB	L	LA
AWM 70	90	74	86±0.02	155.5	68	25	19	20.5	70	G1/8	10	155.5	52	58	9	30.5	52	6H7	8
AWM 90	115	94	110±0.02	195	78	27.5	25	25	86	G1/8	10	195	62	63	11	37	66	8H7	10
AWM 125	155	127	146±0.02	242.5	102	37.5	37	27.5	118	G1/4	12	242.5	82	78	17	47.5	88	10H7	12.5

型号	LB	LC	MA	MB	MM	ML	MN	MK	N	P	Q	R	Z
AWM 70	20	6.6	45	82±0.02	M6	12	6H7	8.5	90	46	50	157.5	223.5
AWM 90	25	9	56	100±0.02	M6	12	6H7	12	110	46	57.5	197.5	273
AWM 125	27.5	11	76±0.02	115±0.02	M8	16	8H7	12	145	46	77.5	259	344.5

135